

To Install **Enveloper**, open WOPRINST.DOC, the Setup Manager for **WOPR**.

Enveloper is perhaps the fanciest AND most useful Word for Windows macro on the Planet. With each new version, the **Enveloper** feature set keeps expanding to bring you more options for your printed envelopes. **Enveloper** is both powerful and easy to use.

Check the Question and Answer section at the end of the document to help you get over some common hurdles.

You may scan through this **Enveloper** documentation "normally" (i.e., sequentially). But if you know which section you want to read, or if you just want to pop around a bit to get more comfortable with **Enveloper**, double-click on one of the sections below: (Start with Section 5 for instructions)

DocCruiser

Section 1.	Section 2.
Section 3.	Section 4.
Section 5.	Section 6.
Section 7.	Section 8.
Section 9.	

DocCruiser,

Pinecliffe International
Advanced Support Group
11900 Grant Place
Des Peres, MO 63131

Orders: (800)-OK-WINWORD (800 659-4696)
Info/Support: (314) 965-5630
CompuServe 70304,3642 or GO WOPR

WOPR © 1991, 94 Pinecliffe International
Artemis Associates, San Jose, CA

1 Introduction

This section includes some introductory information on **Enveloper**, including its features and history.

1.1 Getting Started

To install *Enveloper*,

1. Open the **WOPRINST.DOC** document in your **WOPR** directory and double-click on the sentence at the top of the document.
2. Select **Enveloper 6.0** from the list on the left and click the **Install** button.
3. Choose to install the Toolbar button by clicking **OK**.
4. Click **OK** again to start the second-stage installation. Choose the feed characteristics that closest matches your printer. You can select from a list of common printers. Proceed through the dialog boxes by answering the questions and clicking the **Next>>** button. Click the **Finish** button at the final panel to complete the install. Click on the **Help** button at any time to get detailed help.

Running *Enveloper*:

1. Click on the Envelope Tool in the **WOPRToolbar**. This will enable the *Enveloper* Add-In and run the *Enveloper* macro.
2. Confirm the address, select your envelope, and click the **Print** button to print your envelope.

Customizing *Enveloper*:

1. To speed loading when you start WinWord, *Enveloper* is *not* automatically enabled. You will *not* find the *Enveloper* menu items in the **Tools** menu. To enable *Enveloper*, just click on the Envelope Tool, then click on the **Setup** button to start customization.
 - 1a. You can also click on **File, Templates** to enable **ENVR6.DOT**. Now you can select **Tools, Enveloper6, Customize** from the menu.
 2. Click on **Settings>>** to change *Enveloper's* behavior, such as how it grabs your address, and whether or not to print bar codes.
 3. Choose an envelope from the list and click on **New** or **Edit** to create or edit a custom envelope.
 4. Use the online Help or read the *Customizing Enveloper* section in this document.

1.2 Acknowledgments

Dozens of people have helped make *Enveloper* what it is by contributing ideas, opinions, and comments. In particular, Guy Gallo's original PrintEnvelope 2.1 was our starting point. Though *Enveloper* has gone through a lot of twists and turns since its inception, Guy's pioneering work helped us through a bunch of tough spots.

There are so many other people to thank it's impossible to list them all. Maurice Silberstein, Lee Zeis, Graham Ullrich, Oz Alfonso, Brian Moura, Martin Reddington, Ellen Nagler, Eileen Wharmby, Marc Ullman, Doug Klippert contributed heavily to previous versions of *Enveloper* and many of their ideas still live on in *Enveloper 6*.

Thanks most of all goes to the intrepid registered users of the earlier *Envelopers*. Thanks for your support *and* your suggestions that's made *Enveloper* the best Enve-

lope tool around! This version is, quite literally, our gift to you. Hope you like it! We couldn't have done it without you....

1.3 Features

The features and options of **Enveloper** include:

- Print bar codes to any printer type. Place the at the bottom of the envelope, above the addressee, or below the addressee. It's your choice!
- Print bar codes too! It's those bars just to the left of the stamp. Best of all, you won't get the silly `zip code not valid!` message if you have a foreign address that doesn't have a bar code.
- Print on your envelopes.
- Use multiple (i.e., home and business addresses). You set them up and **Enveloper** remembers.
- Look up an address from with **Enveloper**! A quick button-click and **Enveloper** consults the **WOPR Address Book** utility. You can easily customize it to hook up to your favorite Utility
- Maintain multiple envelopes. Each envelope may be customized for a different situation: , , , , etc. Each envelope can even be customized for a , ensuring perfect envelopes from all your printers.
- a stack of envelopes for your Word for Windows form letters or mailings.
- Use any of the you normally use in your Word for Windows documents for your printed envelopes. You may format the return address and the addressee in any mixture of fonts and choose from bold, italic or underline formatting.
- Choose from dozens of envelope .
- ! A smarter grab than the built into WinWord. You can choose between the two. For those *really* tough addresses, there's still option to have **Enveloper** grab the addressee address from a specified line number.
- Use to send special escape codes to your printer.
- Use the mode to view a model of your envelope on screen before you print.
- Best of all, **Enveloper** is so easy to use that you can start printing envelopes today and explore **Enveloper's** more powerful features tomorrow, as you get more comfortable with how **Enveloper** works.

1.4 *Enveloper's chequered past*

Version 6.0 is another major overhaul of **Enveloper**. It's such a great leap that we decided to skip Version 5.0! (And as a whole, **WOPR** is such a great improvement that we felt we should keep up the big boys jumping from 2.0 to 6.0. <grin>)

The basic multiple-envelope concept of **Enveloper** has not changed in Version 6.0, but there's a major facelift in the user interface. Again, we're taking advantage of WinWord's improved macro language, in particular "dynamic dialog boxes," to give you a tool that's easier and more intuitive to use. One of the most difficult things to change in **Enveloper 4.0** was the printer feed characteristics. With the new **Enveloper 6.0** dialog boxes, you'll have icons that will greatly improve usability (at least a couple of thousand words worth).

Version 4.0 is a major overhaul of **Enveloper**. It takes advantage of the new features available in WinWord 2.0 to create a more powerful, yet still easy-to-use envelope printer. Easy customization is the goal. By utilizing frames — new in WinWord 2.0 — **Enveloper** allows the user to create custom envelope templates. Since envelopes are now true WinWord documents, you can use any font and any graphics that WinWord and your printer driver will allow. A customization macro is provided to allow quick changes to **Enveloper** without a complete reinstall.

Version 3.2 corrects our most embarrassing bug to date: an ampersand ("&") in either the addressee or return address would hang **Enveloper 3.1** out to dry. The hourglass would come on and wouldn't go off. 3.2 also cures our EuroBug: Euro**Envelopers** converting **Enveloper** to metric got an error message — although the error didn't affect processing.

Instead of issuing a maintenance release to hide 3.1's shortcomings, we decided to cram this version with all sorts of new goodies, and get it out the door as quickly as possible. There are new routines and detailed instructions in version 3.2 for printing logos in the "return address" area of your envelopes. Once you get it set up, it's easy! There's a new print merge function for people who want to use their WinWord merge files to print a stack of envelopes at a time. And there's some help for Euro**Envelopers** with LJ II printers: we've found your umlauts!

Version 3.1 (short-lived because of the "&" bug) brought in support for the DeskJet, DeskJet Plus, DeskJet 500, and LaserJet IIISi, including all native fonts on those printers (except, notably, Zapf Dingbats on the LJ IIISi!). It printed POSTNET bar codes on laser printers, so your envelope will get special handling by the USPS. It automatically let you use any font in the PDP 25-in-1 cartridges' repertoire, and it had "hooks" to make it much easier for you to add other hard and "permanent" soft fonts. There were new, detailed instructions for creating and printing "permanent" downloaded Adobe Type Manager soft fonts. And there was a new one-click converter to change **Enveloper** to metric/European envelope sizes — and it almost worked!

Version 3.0 expanded **Enveloper's** scope from an LJ III-specific macro to one that can accommodate the original LaserJet, the LJ II, IIP, IID, III, and IIID, and all 100%-compatible laser printers. It added support for the HP envelope feeder or tray — watch during installation for explanations that pertain to your printer. Version 3.0 also let you print multiple copies of your envelope (thanks to Maurice Silberstein for that idea), turn QwikPrint on during installation (thanks to Lee Zeis for that'n), and change the name of the macro to something other than "**Enveloper**" (Lee at it again).

Version 2.1 corrected a bug in Version 2.0's Installation routine — **Enveloper** would not install correctly if you had checked the "Typing Replaces Selection" box. Version 2.1 also took one of Guy's comments to heart and allowed for the easy disabling of "SkipLines"; Guy thinks SkipLines is a kludge (he's probably right). But lots of us, in

our slovenly ways, use it all the time. And the 3.2 print/merge feature requires it. So **Enveloper** still provides for the use of "SkipLines", but only if you specifically request it during the Installation procedure.

Version 2.0 was a watershed improvement in **Enveloper**, with a new, easy-to-use customizing and installation routine. (Thanks to the hacks at Microsoft and "ISV.-DOC".) Version 2.0 also introduced "QwikPrint", to print an envelope with just one click (thanks again to Maurice).

Version 1.0 was a not-ready-for-prime-time product that delighted those on the bleeding edge. We've come a long way, baby!

1.5 What's New in Enveloper 6

There have been significant changes made to **Enveloper 6**. The changes are meant to make the program more logical and more intuitive to use. Run-time speed is increased at the sacrifice of setup and customization speed. But since you don't customize very often (only at first to set up your standard envelopes), this hopefully won't be too large a sacrifice. In fact, **Enveloper 6** on WinWord 6 seems significantly faster than **Enveloper 4** on WinWord 2.

It is worth reiterating the philosophy behind **Enveloper**.

Philosophy

The philosophy behind **Enveloper's** design is that **ALL** information rest in envelope templates, except for the addressee, of course.

An Envelope template can be described best as a computer model of a preprinted envelope. It contains the , a and/or a . The can be in any that you choose. An envelope template also contains a , its font, the addressee font, and the envelope ; it is even tailored for a .

If you regularly use multiple envelope sizes or return addresses or logos or fonts, simply create different envelope templates for each style. This way, at , you just choose the envelope you want to use and awaaaay you go! All the correct defaults without fiddling.

For example, if you use your business return address and logo for your business envelopes, and your home return address for personal envelopes, you create two envelope templates. At run time, simply select the correct envelope and voila!

You can even build different envelopes that run on different printers! The initial installed printer characteristics only apply to new envelopes that you create. You can actually change the setting on a per envelope basis.

To perform any customization, access the customization dialog box by either choosing **Enveloper6 Customize** from the **Tools** menu, or clicking on **Setup...** when running **Enveloper**. You'll find details in the Section.

1.6 What duzzit do?

Enveloper takes advantage of the *Frames* and *Styles* features of Word for Windows to position and format items on the envelope. Based on your input, **Enveloper** builds envelope templates containing all the necessary frames and macros to print picture perfect envelopes.

These envelope templates can include a , the , and , and selections. All envelope information reside in the envelope templates, with the addressee being the only exception. The advantages to this scheme are numerous. If you use your business return address and logo for your business envelopes, and your home return address for personal envelopes, you could create two separate envelope templates. At run time, just select the correct envelope template and away you go. No more trying to switch return addresses or envelope sizes at . Whether you always print to the same type of envelope or not, envelope templates will speed up the printing of envelopes and give you additional options for your printed envelope. But first things first, onto the process.

2 Installing Enveloper

Welcome to the next generation of **WOPR** and in particular, **Enveloper**! It's gotten a major facelift since version 4, but the basic concept is pretty much the same.....If you can't wait to get started, glance through the notes below in section, then open up **WOPRINST.DOC** and double-click on the Installation sentence! If you've already installed **Enveloper** using the **WOPR Installer**, you don't need to do anything else.

2.1 Before You Begin

If you're a user of **WOPR 2.0**, please make a backup of your **WOPR.INI** in the **WINDOWS** directory before installing. If **Enveloper** makes changes to your **WIN.INI**, the back-up will be saved in **WIN.ENV**.

Enveloper needs some support files when it installs. Please make sure all these files are in the same directory as **WOPRINST.DOC**. These files are:

ENVR6.DOT
ENVR6.HLP
DLLACCES.DLL
ENVR6TPL.SKE
SAMPLE6.ENV
ZIP.TTF

The installer will copy **DLLACCES.DLL** and **ZIP.TTF** to your **WINDOWS/SYSTEM** directory, and your **WIN.INI** may be updated if the **zip** font was not installed previously. The other files will be copied to your envelope template directory.

2.2 Installation

To begin installation, open `WOPRINST.DOC` — the **WOPR Installer** — and double-click the sentence at the top of the document. Select **Enveloper 6.0** from the list on the left and click the **Install...** button. Choose to install the Toolbar Button, and click **OK**. That will bring you to the initial installation dialog box of **Enveloper Installer**.

Choose the mechanism that matches your printer. If you're an **Enveloper 4.0** user, the installer should pick up your current settings. Hopefully the icons are self-explanatory. Use the to find a printer that best matches yours. You can fine-tune by selecting other , the options, and the check-box.

Right-click on an icon to get a short list of matching printers.

Remember that the arrow in each icon indicates the feed direction, so if your envelope feeds from the back of the printer, stare at your printer from the back to match the setting. If your printer feeds from the top, then stare down at it into the feed path.

If you're using an **envelope feeder**, or are on a **DeskJet / BubbleJet / InkJet** printer, make sure the box is checked.

NOTE: The settings you choose here are only for the Sample Envelope and the first envelopes you create. You can change these settings for any number of envelopes to support any number of printers.

NOTE: Use the **<<Back** button to move around the different panes in the Installation dialog boxes. Your settings will be *preserved* as you move around, but they will *not* be saved, and installation will not begin until you click the **Finish** button.

Click the “Next>>” Button to continue Installation

The following sections describe further the elements of the initial installation dialog box. The topics include:

-
-
-
-
-
-
-

2.2.1 Feed Method Icons

These Feed Method Icons indicate the feed mechanism for your printer. Note the location of the arrow in the icon, then stare at your printer, looking in the direction that the envelope feeds into the printer. Match that up with the icon, and you've got the correct setting for your printer.

If your envelope feeds from the rear of the printer, walk around the printer and stare at it from the back. If it feeds from the top, get above it and stare down at it.

You can click the Right mouse button on an icon to see a short list of suggestions. You should use the to make your initial selection.

2.2.2 Printer List Box

This is the drop-down list box right below the list of you see when or **Enveloper**. Begin customizing for your printer by first choosing a printer from this list.

For obvious reasons, we can't possibly list all printers, but the most popular ones are listed, and your printer manual will most likely indicate which one of these your printer emulates.

2.2.3 Face Up, Face Down, Flyer Options

These options are available when you or **Enveloper**. Choose the one that matches your printer.

Note that the *Flyer* option allows you to print an envelope image on 1/3 of a letter-sized page, such that when you fold it up, you get a flyer that you can send out. Choose between Top, Middle, or Bottom by selecting the appropriate after you select this option.

2.2.4 Reverse Landscape

Reverse Landscape printing can be described best as an envelope that prints with the return address *first*.

Printing the return address first minimizes the chances of it being smudged. Some printers automatically print envelopes in this mode. If your printer prints with return address first check the **Reverse Landscape** box.

Other printers may be coaxed into printing in Reverse Landscape. These include printers using the or printer languages. If that matches your printer, also check the **Reverse Landscape** box. **Enveloper** will embed (raw printer code), if necessary, to change the printer mode before your envelopes print.

Note that some printers naturally print envelopes in Reverse Landscape without any help from **Enveloper**, *BUT only* for envelope sizes it knows about! For custom sized envelopes, you may be forced to print in Normal Landscape, or embed Print Fields. Amongst these printers are the Panasonic Lasers and the TI microLasers. Please check your printer manual for details.

If you have problems with this setting, try turning it **OFF**, and enable the setting.

2.2.5 Fit Page to Envelope

If you use an Envelope Feeder, an Envelope Tray, or a DeskJet/BubbleJet printer, you will need the **Fit Page to Envelope** setting. That's because these devices are very picky about what it prints. If **Enveloper** sends it an envelope image that's placed on a letter-sized page (the default), these devices will *assume* that you've made a mistake and will either refuse to accept the input or draw extra sheets of paper through the printer.

Using **Fit Page to Envelope** uses a paper-size that's the same size as the envelope. That satisfies the printer. The drawback here is that you cannot print custom sized envelopes that has a size not recognized by the printer.....and there are a lot of these (envelopes). *Complain to your printer manufacturer!*

2.2.6 Feed Tray

This drop-down list box allows you to choose the printer source from which you'll be feeding envelopes. You'll see it during and of **Enveloper**.

The only caveat is that some Envelope Feeders on some printers have a non-standard setting. Consult your printer manual to find the specific feeder number for your printer. **Enveloper** includes extra settings, **Printer Specific 6** to **Printer Specific 11** for your convenience.

2.3 Reverse Landscape Settings

If you chose a **Reverse Landscape** setup in the initial **Enveloper Install** dialog box to make return addresses print first, you'll be asked if you want to insert to perform the trick.

You have the following options:

- **PCL5 Printer**

Choose this setting if your PCL5 printer does not normally print in Reverse Landscape. **Enveloper** will imbed PCL5 code in your envelopes. Printers that fall into this category are LaserJet III series and LaserJet 4 series printers.

- **PostScript Printer**

You have two options for your PostScript printer. You can either choose to imbed PostScript printer codes, or modify your **WIN.INI** (by adding **LandscapeOrient=270**) to print all landscape documents in Reverse Landscape.

- Choose **Yes** in the bottom half of the dialog box to have **Enveloper Install** automatically modify your **WIN.INI**. This is the recommended setting.
- Choose **No** in the bottom half of the dialog box to embed PostScript printer codes in your envelopes. The default printer code only works on 300 dpi printer! This is *not* recommended, since it requires that you know PostScript and Print Fields. See the section for details.

NOTE: The **LandScapeOrient** setting and **PrintFields** cancel each other out! To use the **LandScapeOrient** setting with your **Enveloper4** envelopes, you must remove the from those envelopes after installation completes.

- **Other Printer**

Choose this setting if your printer normally prints in Reverse Landscape without requiring printer codes. Some IBM Lexmark, NEC, Panasonic, and TI Laser printers fall into this category. Please consult your printer manual.

NOTE: If your printer does Reverse Landscape for envelopes, you may also need the setting to convince your printer that you really are sending an envelope.

Click “Next>>” to continue Installation

2.4 Choosing Options

In this dialog box panel, choose your envelope directory, method, and measurement units. Again, the installer should have picked up your **Enveloper 4.0** settings.

If you choose the same envelope directory as **Enveloper 4.0**, the installer can convert all your envelopes, placing backup in files with the **.EV4** extension. If you choose a different directory, the installer will copy all the **Enveloper 4.0** templates to the new directory before converting, allowing you to use both **Enveloper** versions with both versions of WinWord.

Enveloper now uses points as its internal measurements. Choosing between **inches** and **cm** just tells **Enveloper** to convert from your default units to points.

If you're installing for the first time, or choose a Complete Installation when reinstalling, you can also select between two sets of initial envelope sizes:

- US Envelope Sizes
 - Business Com 10 - 4.125 in x 9.5 in
 - Monarch - 3.875 in x 7.5 in
 - Personal #6 - 3.625 in x 6.5 in
 - Size 9 - 3.875 in x 8.875 in
 - Size 11 - 4.5 in x 10.375 in
 - Size 12 - 4.75 in x 11.0 in
 - Letter-sized Flyer - 3.66 in x 8.5 in
- European / Metric Envelope Sizes

Business DL - 11.0 cm x 22.0 cm
 C5 -16.2 cm x 22.9 cm
 C6 - 11.4 cm x 16.2 cm
 C65 -11.4 cm x 22.9 cm
 Italian - 11.0 cm x 23.0 cm
 Personal - 11.5 cm x 16.0 cm
 Letter-sized Flyer - 9.9 cm x 21.0 cm

Finally, you can choose between two strategies for grabbing addresses from your letters and documents.

-
-

The Microsoft Grab is much faster, so you may want to start with that. But if your address lines are separated by newlines (**Shift+Enter**), the Microsoft Grab method will *still* fail! Choose SmartGrab if that's your situation. If **Enveloper** does have trouble grabbing your address, use **Tools, Enveloper6 Customize** from the menu to change this setting.

Click “Next>>” to continue Installation

2.5 Choose Complete Install and Envelope Conversion

If this is the first time you've installed **Enveloper 6.0**, choose the **Complete Installation**. Enter your first in the Text Box. You may add Return Address later on by using **Enveloper6 Customize**.

If you're an **Enveloper 4.0** user, you won't see the Return Address box. Rather, choose whether or not to convert your **Enveloper 4.0** envelopes. The **Enveloper Installer** will back up your original envelopes using the **.EV4** extension. Keep those in a safe place just in case..... If you choose *not* to convert, only the Sample Envelope will be listed for **Enveloper 6.0**.

If you have a lot of envelopes, the conversion may take a few minutes. Go grab a cup of coffee!

Click “Finish” to proceed with Installation

2.6 Finishing Up

The **Enveloper 6.0** installation will create a completely new section in **WOPR.INI**. It will *not* touch your **Enveloper 4.0** settings. When you are satisfied with the operation of **Enveloper 6.0**, you can manually delete all of **Enveloper 4.0** settings from **WOPR.INI** using an ASCII text editor.

After your new settings are saved, you'll be asked whether or not to install the **zip** font. Please answer **yes**. You can also print a Sample Envelope before conversion starts.

After you've finished installing **WOPR** utilities, choose **Tools, Enveloper6 Customize** from the menu to change , or click on the Envelope Tool to try it out! ENJOY!

2.7 Assigning a Key Combination to Enveloper

If you'd like, you can assign a key combination such as **CTRL+E** or **CTRL+SHIFT+E** to the **Enveloper** and **EnveloperCustomize** macros. To assign a key to the **Enveloper** macro, do the following:

1. Choose **Customize...** from the **Tools** menu. Select the **Keyboard** tab.
2. In the **Save Changes In** list (lower right), choose either **ENVR6.DOT** or **WOPR.DOT** to save the shortcut keys in one of the **WOPR** Add-Ins.
3. From the **Category** list, choose **Macros**.
4. From the **Macros** list box, choose the **Enveloper** macro.
5. In the **Press New Shortcut Key** text box, just type **CTRL+E** (hold down the **Ctrl** key then press the **E** key) or any other combination you want. In WinWord 6, you can use a two key combination, like **CTRL+E, C**.
6. Once you have selected a key combination for the **Enveloper** macro, choose the **Assign** button to add the key combination.
7. Choose the **Close** button to close the Options dialog and return to the Word for Windows editing window.

If you want to remove **Enveloper** from your system (we hope you won't want to), open the **WOPRINST.DOC** document in your **WOPR** directory and run the Setup.

3 Creating a New Envelope

To get you started, this section details two ways you can go about creating and customizing new envelope templates for **Enveloper**.

-
-

3.1 Basing a New Envelope on an Existing Envelope

Once you have created one envelope template it is easy to create new ones. When creating a new template you can choose to base the new template on an existing envelope template. For example, if you've already created a business envelope for domestic mail and want another template for foreign mail that includes the note, **Air Mail**, you can base the new template on the existing one and just change the Envelope Note. Or if you need to print to monarch sized envelopes, you can base the monarch envelope template on the Com-10 Business envelope and then change the size.

To base a new template on an existing template, do the following:

1. Choose **Enveloper6 Customize** from the **Tools** menu.
2. Select the template on which to base the new template. For this example, select **Sample Envelope** from the list of Envelope Descriptions.
3. Choose the **New...** button.
4. In the Envelope Description text field of the following dialog box, enter **Standard Business Com10**. Typically, you should give a descriptive name to help choose the envelope you run **Enveloper**.
5. There is also a list of existing template files ending with the **.ENV** file extension along with a proposed filename for your new template (i.e. **TEMP12.ENV**). Change the suggested name to **BUSINESS.ENV**. If you do not enter a file extension, **.ENV** will be appended.
6. Choose the **OK** button and **Enveloper** will build a new template with the same settings as the original template. You can also choose the **<<Back** button to return to the previous envelope template list for review.

Once the new template is created, **Enveloper** will bring you to the . The top box displays the that you entered previously. The command buttons in this dialog are used to customize the envelope template. The box displays the selected size for this envelope (size of the original envelope). The current and is also listed.

To perform any changes, follow the procedure starting from Step 5 of the following section, .

For more information on customizing an envelope template, refer to page 19 of this section.

3.2 Creating an Envelope From Scratch

The following information details the steps to creating a new business sized envelope with the description "Standard Business". This template is created from "scratch" meaning it is not based on another envelope template.

1. Run the **Enveloper** Customization macro by choosing **Enveloper6 Customize** from the **Tools** menu.
2. Choose **(none)** from the Envelope Description list and choose the **New...** button.

3. You will be prompted for a description and a filename for the new template. For this example, type **New Standard Business** in the Envelope Description box. Type **COM10.ENV** for the filename. Click the **OK** button.
Note: In the background you will see documents being opened and manipulated as **Enveloper** begins to build the envelope template file.
4. **Enveloper** will then bring you to the main customization dialog box. The command buttons in this dialog are used to customize the envelope template. The top box displays the Envelope Description that you entered previously. The Envelope Size box displays the selected size for envelope. The default return address and envelope note are also listed.
5. Choose an envelope size. For this example, click on the Envelope Size drop-down list box and choose **Business Com 10 - 4.125 in x 9.5 in** (European / Metric users should choose **Business DL - 11.0 cm x 22.0 cm**.) Click the **OK** button.
6. If your return address does not appear or is not accurate, click the **Return Addr...** button to change the return address information. Choose the **New...** button to create a new return address or select an address or choose the **Edit...** button to edit the current return address information. Once you have added or edited the return address, click the **Add** or **Change** button.
7. Click **Use for Envelope** button to apply the selected return address to the envelope. Click **<<Back** to get back to the main customization dialog box for additional changes. (You can also click the **Exit&Save** button to end and save the editing for the envelope.)
8. If you would like to change the Envelope Note, simply choose one from the drop-down list.

To add or edit Envelope Notes, click the **Note...** button. Choose the **New...** button to add a new note or choose the **Edit...** button to change the text of the selected envelope note. Click the **<<Back** button to get back to the main customization dialog.
9. Choose the **Fonts & Logo...** button to change the font selections for the envelope text. There are five envelope items that you can choose to configure: **Return Address Line 1**, **Return Address Others**, **Addressee Line 1**, **Addressee Others**, or **Envelope Note**. When you select one of these five buttons, you will be presented with the Format Font dialog box for the selected styles.

Note: **Return Address Others** is based on **Return Address Line 1**. As a result, changing the character formatting for **Return Address Line 1** will also change the formatting for **Return Address Others**. The same relationship exists between **Addressee Line 1** and **Addressee Others**. Choose the **<<Back** button.
10. The Envelope Source drop-down list box near the bottom of the dialog lists the currently selected envelope feed source. If this selection is not correct, change it.
11. Finally, choose the **Exit&Save** button from the main customize dialog. This will save all the changes that you have made to your envelope template file. Select the new envelope description and choose **Set as Default** to set

the new template as the default envelope template. Click **OK** to finish customizing.

The above steps introduces the basic procedure for **Enveloper** customization. There are, of course, more features to each of the separate dialog boxes that you've encountered. If you have questions about a particular part of **Enveloper** (such as bar codes or s), read on to the next sections or refer to DocCruiser for a page reference.

4 Using Enveloper

Once installed there are three ways to run the **Enveloper** macro:

1. Click on the Envelope button on the **WOPR ToolBar**.
2. Choose **Enveloper6** from the **Tools** menu.
3. Press the key combination that you have assigned for **Enveloper**.

When you do one of the above operations, **Enveloper** will try to grab an addressee from the document window before you (the idea here is that after you write a letter, you would run **Enveloper** to print the envelope). **Enveloper** provides three different addressee grab modes for you to choose from: **Grab**, **Find**, or **PhoneBook**. Each has its advantages and disadvantages. The grab methods are discussed in great detail under the **Grab** Section starting on page 21.

Enveloper also provides two buttons, **PhoneBook...** and **Find Zip...** for:

-
-

All you need is to write a couple of functions that grab the info from your utility and return a string to **Enveloper** that represents the updated address. The procedure is described in more detail in the **Grab** and **Find** Sections.

By default, the **PhoneBook...** button is hooked into the nifty Address Book utility that comes with **WOPR**. You can look at the example in the **EnvHooks** macro to adapt it for your Phone Book utility or Personal Information Manager (PIM).

Unfortunately, as of this writing, we were not able to find a reasonable Zip Code utility (in cost and ease of use) that we can hook into **Enveloper**. Nevertheless the hook is there so you may create the hooks yourself, or we can provide an easy upgrade when we do find that utility.

4.1 Enveloper User Interface

After grabbing an addressee, **Enveloper** displays the addressee information for possible changes. You can accept the grabbed addressee or type in an entirely new addressee. You'll see grayed out items reserved for merging when you run it on a main merge document. (The good news is that performing a merge is now as simple as using **Enveloper** itself! See below)

Choose an envelope from the drop-down list. Your default one is chosen initially. (If this is the first time you have run **Enveloper** or you have not created templates to date, then there will be just one template named **Sample Envelope**.) With the desired envelope selected, you can choose the **Print** button to print the envelope without any further interruption.

Click on the **Printer List...** button to get a list of available printers. You can change it for printing the envelope. **Enveloper** will reset to the original printer after it prints. *This function may not work under Windows NT.* If you need to print a lot of envelopes, change the printer using Windows's Control Panel. That will speed up printing considerably, since **Enveloper** does not have to keep changing printers for each envelope.

If the box **Print Bar Code** is marked, then the Zip Code in the addressee will be used to print a bar code that conforms to the U.S. Postal Service's POSTNET standards (see page 34, , for more information on Postal Bar Codes). If your address includes a Zip+4 Code, then the will be printed. Use the **Print FIM A** check box to indicate whether or not to print the bar code (the one to the left of the stamp).

Click on to temporarily change the note for this particular envelope. The addressee area changes to the list of notes. You can choose one from the list or type in a new one. Note that the button text also changes to **Addressee...** Click on it again, and you get the addressee back.

If you choose the button, you'll be dumped into the actual envelope document for manual editing. An additional toolbar will pop up to help you change the and size. You can also print from it. You can even choose from your list of . To get back to the main **Enveloper** screen, click **Cancel**. before you click on **Cancel**, or you'll lose the envelope!

Clicking on **Setup...** brings you to the customization section.

4.2 Enveloper Merge

You have to start with a before you can take advantage of **Enveloper Merge**.

If you have a (and header document) attached, **Enveloper Merge** will pick up the same settings. If you have search criteria defined, they also will be picked up. So theoretically, after you finish your merge letter, all you have to do is click on the Envelope Tool, then the **Print/Merge...** button. A new merge document will be created based on the selected envelope. You'll then be presented w/ the standard merge dialog box to merge to a printer or document, to select range, to change query options.....Instead of **Print/Merge...**, you can also choose **Add to Document** to attach an envelope to your main merge document.

The only things you might want to change are the drop-down lists to choose the merge field that contains the numbered street address and the zip code. This will ensure that the barcodes are generated correctly. You can also modify the merge address by choosing additional fields from the **Append Field** drop-down list; as its name indicates, you can only append to the end of the displayed address.

4.2.1 Step-by-Step Envelope Merging

The key elements you need before merging envelopes are:

1. A that includes your list of addresses.
2. A , representing a letter "model", that specifies where each component from the Data File should be placed.

This section provides detailed instructions on how to set these up and, once set up, how to perform envelope merging. If you already have a main merge document and data file, you can skip to the subsection describing only the envelope merge.

4.2.1.1 Creating a Merge Data File

Word for Windows 6.0 can accept quite a few database formats as the data file of a merge document, ranging from comma-delimited lists to Excel tables to MSAccess data. If you already have a data file, you can skip this section. This section describes a quick way of creating a data file, using the merge engine built into WinWord 6.

1. Create a new file by clicking on the FileNew button in the **Standard** toolbar (far left button, or choose **File, New** and click **OK**).
2. Choose **Tools, Mail Merge...** from the menu.
3. Click on **Create**, choose **Form Letters...**
4. Click on **Get Data**, choose **Create Data Source...** and click **OK**.
5. Give a file name for the data file. You can use **MRGDATA.DOC** or **ADDRESS.DOC**.
6. Click on the **Edit Data Source** button.
7. You're now presented with the Data Form. The number at the bottom indicates which entry is showing, and you can use the arrows to move back and forth. There is only one blank entry now.

Just enter the data, using the **<TAB>** and **Shift+<TAB>** keys to move around. Click on **Add New** to add another entry. When you're done entering data, click on **OK**.

That's it! You're now placed in the main merge document. It should be blank. To enter or edit more data, just click the right-most button in the **Mail Merge** toolbar. See the following section on how to set up the main merge document.

4.2.1.2 Creating a Main Merge Document

Mail Merging in Word for Windows 6 has never been easier. Again if you've already figured out how to do that, you can skip this section.

1. If you've already followed the steps in the previous section, , you can skip to step 4. Otherwise, create a new document and select **Tools, Mail Merge...** from the menu.
2. Click on **Create** and choose **Form Letter...** Click on **Active Window**.
3. Click on **Get Data** and choose **Open Data Source...** Click on **Edit Main Document**.
4. Now you're staring at a blank main merge document. Simply type in the elements you would include in a normal letter. The only difference is for the address block, you would use "merge fields". These fields get filled in with the data from the data file when you merge.

Just as an example, hit the <Enter> key a few times to insert some blank lines.

5. Click on the **Insert Merge Field** on the Mail Merge Toolbar and you'll see a list of the merge fields you can use. Choose **Title**. See how that inserts <<Title>> into the document? After merging, that spot will be replaced by **Mr.**, **Ms.**, **Dr.**, or whatever you've entered in the data file.
6. Hit the <SpaceBar> to insert a space, then click on the **Insert Merge Field** button again and choose **FirstName**. Insert another space and choose **LastName** from the **Insert Merge Field** button. Now hit <Enter> to begin a new line.
7. In this manner, complete the address block to look like:

```
<<Title>> <<FirstName>> <<LastName>>  
<<Company>>  
<<Address1>>  
<<Address2>>  
<<City>>, <<State>> <<PostalCode>>  
<<Country>>
```

8. Enter a couple more blank lines, and type **Dear**. Enter a space, then choose **FirstName** from the **Insert Merge Field** button. Type a comma.

Congratulations! You've completed your first Main Merge document! What? not quite yet? Oh yeah, you want to see the result!

Okay. In the Mail Merge Toolbar, find the icon that merges to a document. It's the one just to the right of the one with the check mark. Place the mouse cursor over the button, and you should see the description pop up: **Merge to New Document**. Click it.

Now it's time for congratulations. You should have a new document that contains multiple copies of your letter, each with a different address, grabbed from your data file!

4.2.1.3 Merging an Envelope

To use *SmartGrab*, choose *Enveloper* Customize from the Tools menu, click on Settings>> and choose *SmartGrab*. Click OK.

Once you have the and the set up, merging an envelope using *Enveloper* is a snap.....If you use *Enveloper's* method of grabbing the address. just doesn't cut it when you go over 5 lines.

1. Activate the window containing the Main Merge document. If it's not opened yet, just open it using **File, Open**.
2. Make sure the **View Merge Data** mode is OFF: It's the **ABC** button in the Mail Merge Toolbar. (Turn this mode ON when you want to print just one record.)
3. Click on the Envelope tool in the WOPR Toolbar. Enveloper will pick up the address block containing your merge fields.
4. Note that the list boxes marked **Field containing street address** and **Field containing Zip code** should select the correct fields. Proper selection ensures that the barcodes will be generated correctly.
5. Click on the **Print/Merge...** button.
6. You'll be presented with the standard Merge interface. You can choose the destination of the merge in the list box at the top left. You can choose **New Document** or **Printer**. Choose **New Document** for this example.
7. Click on **Merge** to complete the merge. When finished, you'll end up with two additional documents: one containing all the resulting envelopes and the other a main envelope merge document.

You can also select the range of Records to merge. Choosing Query Options... gives you even finer control on which records to use in the merge.

If you just want to print a merge letter, only merge envelopes for, say, Christmas or Weddings, you can still follow the procedure in this section. The main merge document can contain only the address block:

```

«Title» «FirstName» «LastName»
«Company»
«Address1»
«Address2»
«City», «State» «PostalCode»
«Country»

```

That wasn't so bad, was it?

5 Customizing Enveloper

Choosing **Enveloper6 Customize** from the **Tools** menu allows you to customize the following features of **Enveloper**:

-
-

The initial dialog box allows you to Create/Edit/Delete envelope templates. Clicking on the **Settings>>** button allows you to change the . Choosing **New...** or **Edit...** brings you to the main customization dialog box where you can make changes to the .

The following subsections describes in more detail the elements of the dialog boxes.

5.1 General Preference Settings

Choose **Tools, Enveloper6 Customize** from the menu, then click on the **Settings>>** button to get to the dialog for changing preferences. Use the **<<Back** button to move around the different panes in the Customization dialog boxes. Your settings will be *preserved* as you move around, but they will *not* be saved until you click **OK**.

5.1.1 User Level

Choose from three different user levels depending upon your familiarity with **Enveloper**.

Beginner is the default setting for **Enveloper**. With this setting there will be warning messages when printing manual-feed envelopes and when entering the **Manual Edit** mode.

Intermediate is what you want if you grow tired of these messages

Expert mode will eliminate *all* dialog boxes. If the **Expert** mode is employed and you click the envelope button, the envelopes will be printed without any intervention on your part. **Enveloper** will use the default template and the default grabbed addressee to print the envelope.

An alternative to the **Expert** mode, would be to create a new macro called something like **QwikEnveloper**. This macro would contain a single line, similar to the following:

```
Sub Main
  Enveloper6.Enveloper(1, 0, "c:\winword\env\com10.env")
End Sub
```

The above macro will run **Enveloper** without prompts and will use the envelope template named **C:\WINWORD\ENV\COM10.ENV**; the full pathname for your envelope template should be used. Alternatively, you can use the second argument as an index into your envelope list. **1** would mean the first one, **2** for the second, etc. As long as it is not zero, the file name is ignored!

Using a **QwikEnveloper** macro will allow you to have both the interactive **Enveloper** and a fully-automated **Enveloper**. This method also allows you to change the default **Enveloper** template without affecting the envelope template used by **QwikEnveloper**.

5.1.2 Addressee Grab Method

Enveloper provides three different options for "grabbing" the addressee information from a Word for Windows document:

-
-
-

Each method has its advantages and disadvantages. After reading through the following explanation of the three grab options you can decide which will work best for you.

After grabbing an addressee, **Enveloper** places the addressee information in an editable dialog box. You can either accept the grabbed addressee or type in an entirely new addressee on-the-fly. If all the chosen grab method fails to grab an address, the addressee text box will be blank. You can type it in manually.

Choose from the menu, then click on the **Settings>>** button to get to the dialog for changing preferences.

5.1.2.1 Microsoft's addressee grab

This is the grab routine used by the Word for Windows internal envelope feature. This method is the fastest of the three, but not always accurate. In particular, this method will not grab your address if the lines are separated by a newline (**Shift+Enter**) character rather than a paragraph mark.

Nevertheless, because Microsoft's addressee grab is the fastest, it is the default setting for **Enveloper**. Its algorithm works as follows:

1. If you have text highlighted, it will be used as the addressee.
2. If you have a bookmark called **EnvelopeAddress**, the contents of that bookmark will be used for the addressee.
3. If you have left justified text that is 3 to 5 lines long, none over 58 characters, it will be used as the addressee. Tabs within the address are not allowed; everything after the Tab is truncated.

5.1.2.2 SmartGrab

SmartGrab performs similarly to the Word for Windows grab routine, but is slower since it uses WordBasic commands to search for the addressee. This method for

grabbing addressee information does, however, result in fewer incorrect "grabs". If you find that is not working for you try the SmartGrab option. The algorithm used by SmartGrab is as follows:

1. If you've selected a block of text **Enveloper** grabs the selected text and uses it as the addressee. The selection must be more than 10 characters long, and long addresses will be truncated to 215 characters.
2. If you have a defined bookmark called **NameAddress** (which is a common name in the Word for Windows templates), **Enveloper** will grab the bookmark text as the addressee (again, truncated at 215 characters).
3. If you have a defined bookmark called **EnvelopeAddress** (which is the name used by Microsoft's Envelope routine), **Enveloper** will grab everything in that bookmark as the addressee.
4. And finally as a last resort, the text meeting the following criteria will be grabbed:
 - Left-justified
 - Three or more non-blank text lines that do not include a picture nor are part of a Word for Windows table.

5.1.2.3SkipLines

SkipLines is the most rigid of the three methods. The idea here is that you indicate how many lines you want **Enveloper** to skip (from the beginning of file) before **Enveloper** starts to look for non-blank text to be used as the addressee. SkipLines is used only if steps 1 through 3 of fail.

5.1.3Bar Code Options

There are two check boxes you can choose to indicate whether or not barcodes should be printed on your envelopes. Check the **Print POSTNET Bar Code** box if you want the bar codes printed. Check the **Print FIM A Bar Code** box if you want the bar code (it's the thing just to the left of the stamp.) The default is to check both boxes.

Note that if your addressee does not contain an US address with a zip code, no barcodes will be printed regardless of these settings.

To find out more about POSTNET bar codes, look in the Section.

5.1.4ALL CAPS Addressee

According to the official USPS specs, it's best if the addressee is in ALL CAPS and a non-serif font, such as Arial, Helvetica, etc. (Yecch!) So.....there a setting to do that.

Check the box marked **Addressee in ALL CAPS** in the **Settings>>** section of **Enveloper6 Customize**.

Technically, abbreviations should also be used, like **CIR** instead of **Circle**, **FLS** instead of **Falls**, **BSMT** instead of **Basement**, etc. Well.....**Enveloper's** not going to do that for you. Sorry.

The default for this setting is OFF.

5.2 Envelope-Specific Settings

Following the steps in the Creating a New Envelope section will also bring you to the customization dialog box.

To change envelope-specific settings, such as the , , or , choose **Tools, Enveloper6 Customize** from the menu, select an envelope from the "Envelope Description List", and click **Edit...** This will bring you to the "Main Customization Dialog Box."

As you make changes to various parts of the envelope, you'll be presented with different "panes" of the dialog box. You can press the **<<Back** button from these secondary panes to get back to this Main Customization Dialog Box; the changes you've made in the secondary panes will be preserved. To save the changes to the envelope, click **Exit&Save**. This will also exit the Customization Dialog Box and get you back to the Envelope Description List. Note that you can click **Exit&Save** from any of the panes to save all changes. If you click **Cancel**, all changes will be discarded and you'll be presented with the Envelope Description List again.

You can also click on **Test Print** to print a sample of the envelope, or **Manual Edit** to enter mode.

The following subsections describe briefly the procedure for changing the different settings of your custom envelope.

5.2.1 Envelope Description

The Envelope Description is the text assigned to explain the envelope template. This might be something as generic as "Personal Envelopes" and "Business Envelopes" or something more specific like "Monarch Bulk Mailing Envelopes" or "Special Festive Envelopes on DeskJet".

To change the Envelope Description that now appears at the top of the , just type in the text box.

5.2.2 Envelope Size

The Envelope Size is the physical dimensions for your envelope (height and width). To change the envelope size for the current envelope, just choose a size from the **Envelope Size** drop-down list box.

HINT: You can delete sizes that you do not plan to use to speed up initialization of the Envelope Customization macro.

What? Can't find one that matches? Click on the **Size...** button to create new envelope sizes.

Click on the **New...** button to create a new envelope size description and dimension. In the **Envelope Size Description** text box, enter text to describe the size and/or type of envelope you are using. An example of this might be **Business Com 10 - 4.125 in x 9.5 in**. This type of description is not mandatory, but is a helpful when you must choose the size from the **Envelope Size** drop-down list box of the .

The two smaller text boxes are for the actual height and width of the physical envelope. You will want to measure your envelope and enter the appropriate values.

When you're satisfied, click **Add**. This will add the new envelope size to the end of the list. If you decide not to add a new size, click **No Change**. After adding a new size, you may select the new size from the list and choose **Use for Envelope** to use this size for the current envelope and get back to the Main Customization Dialog Box.

In addition to the **New...** size, there are the **Edit...** and **Delete** buttons to allow you to edit an existing envelope size, or to remove the selected size from the envelope-size list. If you edit an existing envelope size, click **Change** to apply the change or **No Change** to discard the edits.

You can also set a default envelope size for new envelopes created from scratch. To set a size as the default, select it and click the **Set as Default** button.

Note: Changing the envelope size may change your logo and return address placements.

5.2.3 Return Address

The return address for your envelope is displayed in the **Return Address** box. Choose the **Return Addr...** button to choose another return address, or to change and add new return addresses.

To choose a return address for the envelope, select one from the list and click on **Use for Envelope**. If you do not need **Enveloper** to print a return address, as in the case of pre-printed envelopes, choose **(none)** from the Return Addresses list.

The process of changing return addresses is very similar to that of changing :

- To edit an address, select the address from the list and click the **Edit...** button.
- To add a new address, choose the **New...** button.
- Choose the **Delete...** button to delete the selected return address.

HINT: The Change button appears when you Edit a return address, and the Add button appears when you Add a return address.

Choosing the **Edit...** or **New...** button will allow you to change or enter the return address in the bottom half of the dialog box. Click on **Change** or **Add** to apply the changes, or **No Change** to discard them.

The current default address is listed at the bottom of the dialog box. To set the default address, select an address from the Return Addresses list and click the **Save as Default** button.

5.2.3.1 Invitation Envelopes

Envelopes for invitations often have the return address printed on the flap.....on the back side of the envelope. We really want to help out here, but we couldn't think of a way to do it in one pass through the printer. We *could* tell you to open the flap so we can print the return address, upside-down, on the flap, but we didn't think your printer would appreciate that glue going through your rollers.....

As a compromise, **Enveloper** provides a check box marked **Horiz Center Return Address**. This will allow you to define a separate envelope template to print on the back flat, horizontally centered. This allows you to turn all your envelopes over to print *just* the return address with *NO* addressee or barcodes. Then turn them over again to merge your addresses to the envelope, using another envelope template for the front side (no return address).

5.2.4 Enveloper Fonts

NOTE: The EnvAddresseeRest style is based on the EnvAddressee style. This means that if you want all of the lines for the return address to look alike, you will only need to change EnvAddressee. Similarly, the EnvRetAddrRest style is based on the EnvRetAddr style.

Enveloper maintains 5 different font styles for your envelope:

- **EnvAddressee** — for the first line of the addressee
- **EnvAddresseeRest** — for all other lines of the addressee
- **EnvRetAddr** — for the first line of the return address
- **EnvRetAddrRest** — for all other lines of the return address
- **EnvNote** — for the envelope note

You can change these fonts using **Enveloper's** convenient command buttons.

From the , click on the **Fonts & Logo...** button. Choose any of the five button in the top half of the dialog box to change the fonts. You'll be presented with the standard Word for Windows' FormatFont dialog box.

Choose from any of the font attributes in the dialog box (font name, font size, bold, italics...) and look for the result in the lower right preview image. Change as many attributes as you like and select the OK button. You then can customize another envelope element or choose the <<Back button to return to the Main Customize Dialog Box.

5.2.5 Logo

Although you can add any graphics or additional text to your envelopes, **Enveloper** can help you manage one logo for each of your custom envelopes. Click on the **Fonts & Logo...** button in the . If the envelope contains a logo being managed by **Enveloper**, the Logo **Filename** text box will contain the filename of the logo; otherwise, it will be blank.

Note: Whenever you perform a logo operation, all envelope item positions will be re-set to predetermined locations. As a result you may need to use the **Mode** to fine tune the placement of items on your envelope.

5.2.5.1 Insert or Replace

To add a logo/graphic on your envelopes, do the following:

1. Choose the **Insert or Replace...** button.
2. The Word for Windows' Picture dialog will pop up asking you to choose a graphics file. To limit your file search choose the type of graphic you will be inserting from the **List Files of Type** drop-down list box. Click on **Preview Picture** to see a preview. After selecting a logo file, click **OK**.
3. You will then be prompted for the logo size. The full-size dimensions are listed in the text boxes. Make any changes you like. Click on the **Reset to 100%** button to reset the dimensions to the full-sized picture.
4. Choose the **Logo Position** for the logo. The two options are
 - Left of Return Address
 - Above Return Address
5. Click **OK** to apply the changes. Click **<<Back** to return to the Main Customize Dialog Box.

HINT: Leave one dimension blank to equally scale both dimension.

HINT: Like other envelope elements, the position of the Logo can be manipulated in the **Enveloper Manual Edit Mode** (see Section 5).

5.2.5.2 Resize and Reposition

To resize or move your logo, click on the **Resize or Reposition** button. Enter the appropriate dimensions for the logo, choose the position. Follow the instruction in the previous section, .

When satisfied, click **OK**, then **<<Back** to get back to the .

5.2.5.3 Delete Logo

Finally, you can remove an existing logo by choosing the **Delete** button.

5.2.6 Envelope Note

Enveloper lets you select a note to place on your envelopes. From the , just select a note from the **Envelope Note** drop-down list box. Choose (**none**) for a blank note. If you do not find a note to your liking, click on the **Note...** button.

HINT: You can speed up initialization of the Envelope Customization macro by deleting unused notes.

The process of changing the envelope note is very similar to that of changing **and** :

- To edit a note, select the note from the list and click the **Edit . . .** button.
- To add a new note, choose the **New . . .** button.
- Choose the **Delete . . .** button to delete the selected note.

HINT: The Change button appears when you Edit a note, and the Add button appears when you Add a note.

Choosing the **Edit . . .** or **New . . .** button will allow you to change or enter the note in the bottom half of the dialog box. Click on **Change** or **Add** to apply the changes, or **No Change** to discard them.

The current default note is listed at the bottom of the dialog. To set the default note, select an one from the Envelope Note list and click the **Save as Default** button.

Clicking on **Use for Envelope** will use the selected note for the current envelope and return you to the Main Customization Dialog Box.

Like other envelope elements, the position of the Note can be manipulated in the **Enveloper Manual Edit** Mode (see the Section)

5.2.7 Envelope Feed Tray

Choose the feed tray for your envelope from the **Envelope Feed Tray** drop-down list box in the . Click on the **Set Default Tray** button to set the selected tray as the default for new envelopes created from scratch.

Different envelope template may use different envelope sources. For example, if you have a dedicated envelope feeder for your business envelopes, you can configure your business envelope template for **Envelope Tray**. If you hand-feed your personal envelopes, you would configure your personal envelope template for **Manual Feed**.

Note: Some special printers and printer drivers have feeders that require you to know the specific feeder number. Consult your printer manual for this number and choose one of the special feeder numbers up to eleven (**Printer Specific 6** to **Printer Specific 11**).

5.2.8 Printer Feeder Settings

There are a lot of printers out there, and you need to let **Enveloper** know which type you have so it can figure out how to place the envelope image correctly. These printer-specific settings are stored with each envelope, so you can customize different envelopes for different printers.

For example, if you have a DeskJet and a laser printer that you use to print envelopes (maybe it's a *color* DeskJet), you can make separate envelope templates, each tailored to its own printer. Once you're running **Enveloper**, just choose the envelope template that matches the currently selected printer.

To change the Printer Feeder Settings, click on the **Printer & Zip Settings . . .** button.

When finished with your changes, you can click the <<Back button to return to the to make other customizations, or click the Exit&Save button to save all the changes to the envelope.

5.2.8.1 Feed Method

You may change the printer feed characteristics of individual envelopes to match a particular printer. This provides multiple printer support in a limited way.

NOTE: Existing envelope templates will not be affected by the new settings. You will have to change each envelope separately.

Select the that matches the feed characteristics of your printer. To get started, choose a printer from the that closely matches your printer. You can also point the mouse cursor at an icon and click the right mouse button to get a hint.

Click on the **Set as Default** button to make these settings apply to new envelopes created from scratch.

Check the button to minimize smudging by printing the return address first. This setting requires that you have a printer that can support this mode. If you have a print using the PCL5 printer language (LaserJet III and LaserJet 4 and compatible), or a PostScript printer, then you can use this mode.

Enveloper uses to support Reverse Landscape on some printers. If you find that your return address is not printing first, check the Print Field button to make sure an appropriate print field is selected. Please see the Section for more information on Print Fields.

5.2.8.2 Fit Page To Envelope

HINT: DeskJet printers and envelope feeders and envelope trays require the Fit Page to Envelope setting.

Choosing the **Fit Page to Envelope** checkbox will tell **Enveloper** to use a page size that matches that of the envelope. This is important if you're using an envelope tray or envelope feeder. You also need this setting for DeskJets.

NOTE: Existing envelope templates will not be affected by the new settings. You will have to change each envelope separately.

Enveloper normally creates envelopes using a letter-sized page to ensure that the feed position of the envelope will remain consistent regardless of the envelope size. This also allows you to create custom-sized envelopes not supported by the printer. Unfortunately, some printers are too smart (or too dumb, depending on your point of view); they will refuse to accept a letter-sized page when they are set up to accept envelope. The consequence is that you won't be able to print custom-sized envelopes on these printers. (Hey, complain to the printer manufacturer!)

Click on the **Set as Default** button to make these settings apply to new envelopes created from scratch.

5.2.8.3 Minimum Margins

Most printers cannot print to the edges of a page. There are usually minimum margins required by each printer driver. **Enveloper** attempts to maintain margins that will satisfy most printers. If you find that your printer driver is giving you warning mes-

sages, you might want to change the minimum margins settings until the messages go away.

You might also want to change the top margin value to get your return address printed closer to—or farther from—the envelope edge; this is especially true for portrait mode printers.

To find the proper settings for your printer, use the Window's **Write** application. (Never thought you'd need that again now that you have WinWord, huh?):

1. Open a new document
2. Choose **Tools, Macro...** from the menu. Make sure the "Macros Available In" list indicates "**All Active Templates**".
3. Select **WOPRMinMargins** from the list. Click **Run**.
4. Choose **Portrait** or **Landscape**, which ever matches how your printer prints envelopes. Choose **Current Printer Size** and click **OK**.
5. Make a note of the minimum margins, because we need to register them with **Enveloper**.
6. If you use setting for your envelopes, also try the above by using **Com10 size** setting.

Make a note of both settings to try. WinWord 6.0 has a bug in that it always uses the first set of minimum margins (step 4), when it should be using the second set (step 6) for envelope-sized documents. You may need to mix the two sets of numbers by choose the larger value in each dimension to make both WinWord and your printer happy.

NOTE: Existing envelope templates will not be affected by the new settings. You will have to change each envelope separately.

Back in , click the **Printer & Zip Settings...** button from the and enter the margins values.

Click <<**Back** to return to the Main Customization Dialog Box to make other changes or **Exit&Save** to save all changes to the envelope.

Click on the **Set as Default** button to make these settings apply to new envelopes created from scratch.

5.2.9 Zip Barcode Settings

Enveloper allows you to place the POSTNET barcode in three accepted locations:

- At the bottom of the envelope
- Above the addressee
- Below the addressee

Click on the **Printer & Zip Settings...** button from the and choose your setting. Click <<**Back** to return to the Main Customization Dialog Box to make other changes or **Exit&Save** to save all changes to the envelope.

Click on the **Set as Default** button to make these settings apply to new envelopes created from scratch.

If you choose to print the bar codes at the bottom of the envelope, you can fine-tune the position to make it print correctly on your printer. The next subsection gives the official specs.

5.2.9.1 USPS Requirements and Bar Code Position

NOTE: DeskJets and Dot-matrix printers probably will not be able to print the barcodes at the bottom of the envelope. Use the Above Addressee setting.

The United States Postal Service has a formal requirement for the position of the postal bar code on the envelope.

Vertical Placement: The distance from the bottom of the printed bar code to the bottom of the envelope should be 1/4 inch plus or minus 1/16 of an inch.

Horizontal Placement: Measure the distance from the leftmost printed bar code to the right edge of the envelope. This distance should be between 3.25 and 4.0 inches.

If your sample envelope with a printed bar code does not comply to the above requirements, you may need to customize the placement of the printed bar code.

Click on the **Printer & Zip Settings...** button from the Main Customization Dialog Box to bring up the barcode position settings. The default positions are:

Horizontal Placement: 288pt or 4 inches from the first bar to the right edge of the envelope.

Vertical Placement: 30pt or approximately .5" from the top of the first bar to the bottom edge of the envelope.

The units are in points with 72pts = 1 inch and 28.35pts = 1 cm.

NOTE: Existing envelope templates will not be affected by the new settings. You will have to change each envelope separately.

Clicking the **Reset** button will return the setting to these values.

Click **<<Back** to return to the to make other changes or **Exit&Save** to save all changes to the envelope. Click on the **Set as Default** button to make these settings apply to new envelopes created from scratch.

5.2.10 Print Field

Enveloper allows printer codes to be imbedded in an envelope to directly control printer actions. This is how is performed for some printers. It can even correct for faulty printer drivers, such as the DJ550C driver, that fail to enable Envelope Feed. Most users need not be concerned with this feature, so the details are deferred to the Section.

Note that some printers drivers cannot accept printer codes. Among these is the Windows Printing System (WPS). If you're using the WPS, it means that you *cannot* print envelopes in Reverse Landscape.

To assign a Print Field to your envelope,

1. Choose **Tools, Enveloper6 Customize** from the menu.
2. Select your envelope and click **Edit...**
3. Click on the **Print Field...** button.
4. Choose a Print Field from the list. If you want to remove a Print Field, choose **(none)**.

5. Click on **Exit&Save** to save the changes.

If you do not find a Print Field to suit your needs, you may need to create a new one. See the section for more details.

6 Manual Editing

In *Enveloper 4.0*, this was called the **Preview Mode**. Whenever you open an envelope template, you'll get an additional toolbar that's always available for you to help you edit your envelope.

Do not use Ctrl+F4 or double-click on the Control Menu (the "hyphen box") to close the document!

Instead, choose **Cancel**, or **Exit&Save** from the toolbar. To print the envelope, choose the Print tool button in the **Enveloper Manual Edit** Toolbar.

The **Manual Edit** mode allows you to view your envelope in the Page Layout view of Word for Windows. This not only allows you to visualize your envelope, but also reminds you how your envelope feeds into the printer in relation to your regular letter sized (or A4 sized) paper. Envelope borders are drawn to help you better visualize your envelope.

In the **Manual Edit** mode, you view the layout of your envelope and reposition envelope items as necessary. You can move the envelope items anywhere you want on the envelope, and format the text items as you would like. There are really only two rules to remember when working in the **Manual Edit** mode of *Enveloper*:

1. Never manually delete any item from the previewed envelope. If you wish to delete an item such as a return address or logo, do so from the **EnveloperCustomize** dialog boxes. Deleting items from the **Manual Edit** mode may cause unpredictable results when *Enveloper* is working with your Envelope template.
2. Use the **Enveloper Manual Edit** Toolbar buttons when formatting changes other than repositioning frames on the envelope. This toolbar should appear whenever you open the envelope template.

You enter the **Manual Edit** Mode of *Enveloper* in several ways:

1. While customizing an envelope template using **EnveloperCustomize**, click on the **Manual Edit** button.
2. While running *Enveloper* itself, click on the **Manual Edit** button.
3. Opening up an envelope template (.ENV file) using **File, Open**.

The mechanics are the same for any of the methods, but there are subtle differences. The primary difference being that changes made at are *not* saved to the envelope template unless you explicitly save them with the File Save command.

To exit **Manual Edit** mode, click on the **Cancel** or **Exit&Save** button of the **Enveloper Manual Edit** toolbar.

6.1 Enveloper Manual Edit Toolbar

The **Enveloper Manual Edit** Toolbar appears whenever you enter **Manual Edit** mode, or when you open an Envelope Template. If you do not want to see the toolbar anymore, just click on the little square to the left of the toolbar's title.

The **Enveloper Manual Edit** Toolbar contains the following buttons:

- **Exit&Save** — Exit **Manual Edit** mode and save changes
If you entered this mode when using **Enveloper6 Customize**, then you'll return to the Main Customization Dialog Box.
If you entered when using **Enveloper** at run-time, then you will be returned to the main **Enveloper** interface.
If you manually opened the envelope template by using **File, Open**, then the template will be saved, then closed.
- **Cancel** — Exit **Manual Edit** mode; don't save changes
If you entered this mode when using **Enveloper6 Customize**, then you'll return to the Main Customization Dialog Box. The changes you've made are still kept unless you click **Cancel** again in the Main Customization Dialog Box.
If you entered when using **Enveloper** at run-time, then you will be returned to the main **Enveloper** interface. The envelope is closed and deleted.
If you manually opened the envelope template by using **File, Open**, then the template will be close, discarding changes.
- **Print** — Print the envelope
- **Return Address Line 1 Font** — Change the font of the first line of the return address
- **Return Address Other Lines Font** — Change the font of the other lines of the return address.
- **Addressee Line 1 Font** — Change the font of the first line of the addressee.
- **Addressee Other Lines Font** — Change the font of the other lines of the addressee.
- **Return Address and Note Lists** — Get the Return Address and Envelope Note list for quick changes while in **Manual Edit** mode. Note that the button reads **RET & NOTE LISTS**, and the "help" text says a very intuitive **Env RAand Note** (tongue firmly planted in cheek).
- **Resize Logo** — Resize and reposition the logo, if any. If there are no logos, you get a warning. You cannot add a logo that is managed by **Enveloper** while in **Manual Edit** mode, but you can add any other graphics or text... ..you just won't be able to use the **Enveloper** convenience buttons to resize and reposition them.
- **Help** — Get the **Enveloper** help file.

6.2 Formatting in Enveloper's Manual Edit Mode

If you need to change the fonts or resize the logo, use the tool buttons in the **Enveloper Manual Edit** Toolbar. If you need to move the items in the envelope, drag its frame around, or use the **Format**, **Frame** menu command.

Actually, if you're familiar with WinWord Styles, you should choose **Format**, **Style...** from the menu, then click on **Modify...**, then **Format** then **Frame...** to change the frames' sizes and locations.

6.2.1 Format Fonts

Hopefully, the icons in the toolbar are clear. Words just took up too much space. The red line in each button image is supposed to indicate which font the button is supposed to affect:

Return Address, 1st line
Return Address, Other lines
Addressee, 1st line
Addressee, Other lines
Note

Note that these buttons are simply convenient interfaces to change the Font Style of the **EnvAddressee**, **EnvAddresseeRest**, **EnvRetAddr**, **EnvRetAddrRest**, and **EnvNote** styles.

Sorry, there's still only two font styles for each address block.

6.2.2 Resize Logo

The **Resize Logo** button allows you to resize your logo as in the **EnveloperCustomize** dialog box. If your graphic is too large or small for the envelope choose this button to resize the logo to the necessary dimensions. Leaving one dimension blank will scale both dimensions equally. Choose the **Reset to 100%** button to reset the graphic to its original import size.

From this dialog box, you can also choose to place the logo to the left or above the return address.

6.2.3 Print Envelope

The print routine behind the Printer tool button takes a bit longer than normal **Enveloper** print. This is because **Enveloper** needs to remove the envelope borders before sending the page to the printer (the borders are added when entering the **Manual Edit** mode).

6.2.4 Change Return Address and Note

There's also a tool button called **RET & NOTE LISTS**. Clicking on this button brings up two drop-down list boxes from which you can choose to change the return address and note.

6.3 Repositioning Items in Manual Edit Mode

Enveloper's default positioning for items is usually correct for most envelopes you might want to create, but there are always exceptions. The elements that make up *Enveloper*, the addresses, the logo, and the note can all be repositioned in the *Manual Edit* Mode. The following steps outline the steps to repositioning the addressee information:

1. Choose **Enveloper6 Customize** from the **Tools** menu.
2. Select the envelope template to edit, and choose the **Edit...** button.
3. Choose the **Manual Edit** button.
4. Locate the addressee information and click on the address once with the mouse. This should select the address so that a box appears around the address.
5. Position the mouse cursor near the edge of the box so that the mouse cursor changes to a four-sided arrow. Now, click and drag with the mouse to reposition the addressee.
6. You have now successfully moved a framed object in the *Manual Edit* mode.
7. Choose the **Exit&Save** button from the *Enveloper Manual Edit* toolbar to exit *Manual Edit* mode with your changes intact.

Note that instead of manually dragging the frame, you can also use **Format, Style** from the menu. Replace step 5 above with the following:

- 5a. Choose **Format, Style** from the menu.
- 5b. Highlight the style associated with the item you want to move. The style names all begin with the letters **Env**.
- 5c. Click on the **Modify...** button. Click on **Format** button, then select **Frame**.
- 5d. Change the values in the **Horizontal Position** and **Vertical Position** boxes.

7 POSTNET Bar Codes

With *Enveloper*, you have the option of printing bar codes,

(called "POSTNET" codes) where the United States Postal Service would like them printed on envelopes. Additionally, you can print the barcode,

at the top of the envelope just to the left of the stamp.

These are enabled by default. To change them:

1. Select **Enveloper6 Customize** from the **Tools** menu.
2. Click on the **Settings>>** button.
3. Change the **Print POSTNET Bar Code** and **Print FIM A Bar Code** checkboxes to suit your liking.

These are global settings. Your envelope templates still contains the visible bar codes. They will be removed at run time when you print your envelopes or add an envelope to a document.

See the following subsection to get further explanation of the bar codes.

7.1 Why Bar Codes?

Most sorting stations of the United States Postal Service (USPS) have equipment that reads and analyzes bar codes. These bars are simply another representation for the digits in your bar code. Envelopes that are not pre-printed with bar codes are sorted manually by the United States Postal Service. Envelopes that have postal zip codes pre-printed on them can be sorted by sophisticated machinery instead of by hand. In theory, envelopes with pre-printed bar codes will arrive at their destination earlier than others, due to the fact that they will not need to be manually sorted. And if nothing else, printed bar codes make your envelopes look slick and professional while lessening the burden of sorting mail on the part of the USPS.

7.2 DPBC

The USPS recently started using the Destination Point Bar Code (DPBC). In addition to the Zip+4 barcode, the DPBC contains an additional set of bars that represent the last 2 digits of your street address. You don't need to worry about it. If **Enveloper** and WinWord can find the digits, they will be used to generate your bar code.

7.3 FIM A

The FIM bar codes are placed next to the stamp to give barcode readers an idea of the orientation of the envelope (which side is up), and what type of envelope. The FIM A is just means that there is a POSTNET bar code on the envelope, and that the envelope requires a stamp.

There are also FIM B and FIM C bar codes, but they 99.9% of **Enveloper** users will not need them. FIM C is used for Business Reply (prepaid) envelopes, and FIM B is for reply envelopes that don't contain POSTNET barcodes.

7.4 Are Postal Bar Codes For Me?

Postal Bar codes are for anyone who meets the following criteria:

- You need to reside in the United States and mail envelopes to others who reside in the United States (sorry postal codes for US residents only).
- Own a printer with the capability of printing graphics (sorry no bar codes to daisy wheel printers).

7.5 Bar Codes, How Does Enveloper Do It?

Well.....actually, WinWord 6 made it much easier for us. We don't have to jump through too many hoops, since WinWord not supports barcodes using a special BARCODE field. The only thing Microsoft screwed up is that if your address does not contain a US zip code, the field generates `zip code not valid!` Imagine doing a mail merge that contains Canadian envelopes; you'd wind up with envelopes that contain that ugly message!

Enveloper has a workaround! We format the field to be the `zip (TrueType)` font, provided with WOPR. This font has no characters defined for any of the characters in the error message, so nothing will print. Soooooo.....if you do see the `zip code not valid!` on your printed envelopes, make sure the `zip` font is installed correctly using Windows Control Panel Fonts utility.

7.6 USPS Requirements and Bar Code Position

The USPS allows the POSTNET barcode to be located in several places on the envelope:

- At the bottom of the envelope
- Above the addressee
- Below the addressee

Please refer to the Section to see how to set the barcode position for each envelope.

8 Advanced Topics

This section provides more details and programming information for advanced topics. These include:

-
-

-
-

8.1 Print Fields

Print fields are an advanced feature that may be best left those who understand printer escape commands. Print fields are printer-specific commands that are sent directly to the printer, without any embellishments from Word for Windows. One use for this feature is to enable the `mode` on Hewlett Packard LaserJet III, LaserJet 4, and PostScript printer. The **Reverse Landscape** mode allows the return address to be printed at the leading edge of the envelope. This particular mode is *automatically* enabled during installation (*Enveloper* Installation asks which fields you want to use.)

The print fields are sent to the printer *before* printing any item on the envelope, so that whatever the print field commands the printer to do will be in effect when the rest of the envelope is printed. You can see the print field codes in the `Mode` by selecting **View, Draft**, then **View, Field Codes** from the menu.

To place a print field into an envelope template, do the following:

1. Choose **Enveloper6 Customize** from the **Tools** menu.
2. Select the appropriate envelope from the description list and choose the **Edit...** button.
3. Choose the **Print Field...** button from the Main Customization Dialog Box. The resulting dialog will list the descriptions for the field codes already entered into *Enveloper*. There are buttons to **Edit**, **Delete** or create a **New** print fields for your envelope.

Note: LaserJet III owners should make sure the **PCL5 Reverse Landscape** field code is the default. This way, the appropriate print field will automatically be inserted every time you create a new envelope. To ensure this is the default, select the field and click the **Save As Default** button.

8.1.1 Editing or Creating Print Fields

Editing or creating Print Fields involves two steps. You will need to supply a description for the print field (e.g.,) and the actual printer code itself (the printer instructions). If you were to view the printer code for the PCL5 Reverse Landscape description (choose the **Edit...** button), you would see the following code:

```
print "Esc &a180P Esc &l1E "
```

Instead of using a `Chr$(27)` to indicate the **Escape** character, just type `"Esc "`; note that the trailing space is required. At run time, this `Esc+Space` is converted to `Chr$(27)`. For more information on appropriate printer codes, you will need to consult your printer documentation.

8.1.2 More on the PCL

Hewlett Packard and compatible printers speak a language called PCL. A PCL5 printer code is used to access the mode for LaserJet III and LaserJet 4 Series printers. A PCL5 example sequence is as follows:

```
Esc &a180P
```

This sequence will rotate the page 180 degrees. That is, turn the page upside down.

The print field code for **PCL5 Reverse Landscape** is a combination of two sequences: one to rotate the page and one to adjust the top margin:

```
Esc &a180P Esc &l1E
```

In order to make the envelope print out correctly in reverse landscape mode, you may also need to adjust the top margin. If you select a LaserJet III model during installation, then the top margin will be automatically adjusted during installation..., but here is an explanation just the same:

When printing using **Reverse Landscape**, the printed page is shifted *down* by about two lines. As a result, the margin needs to be reset to a smaller number. On a LaserJet III, a margin of 1 line seems to do the job effectively and the code for that is:

```
Esc &l1E
```

which makes up the second half of the **PCL5 Reverse Landscape** print field.

8.1.3A Note on PostScript

In Windows 3.0, PostScript printer naturally printed in . The Windows 3.1 PostScript driver, however, turned things upside down, literally! The easiest fix to force **Reverse Landscape** by adding a line to your WIN.INI file. Look for the section starting with *[Devicename,Port]*, where *Devicename* matches your printer and *Port* is your printer port. Add the line, **LandScapeOrient=270**. For example:

```
[HP LaserJet III PostScript,LPT1]  
LandScapeOrient=270
```

Again, **Enveloper** Install will enter this for you if you tell it to. If you wish to do this (recommended), then you must remove any **Reverse Landscape** printer codes from each of your envelopes:

1. Choose **Enveloper6 Customize** from the **Tools** menu.
2. Choose an envelope then click the **Edit...** button
3. In the Main Customization Dialog Box, click **Print Fields...**
4. Select **(none)** click on the **Save as Default** and click **Use for Envelope**.
5. Click **Exit&Save** to save the envelope.
6. Repeat steps 2 through 5 for each envelope.

If you don't wish to turn all your landscaped documents upside down, then you need to imbed some printer field codes. The following instructions describe the process for embedding PostScript **Reverse Landscape** codes.

This is not as easy to do for PostScript printers, since there is not a simple escape code to accomplish this. The exact code will have to depend on the page size you're using to create your envelopes *and* your printer resolution. If you do not use the **Fit Page To Envelope** mode, you can use the provided Print Fields to perform **Reverse Landscape**.

Some examples and explanations are provided on the following page.

For US users using letter-sized paper for envelopes, the required code is:

```
{print "11 .52 sub 300 mul 8.5 .5 sub 300 mul translate
180 rotate "}
```

Let's see how we arrived at these numbers. Use the following figure as a guide. The dimensions of the letter-sized paper is 11.0" x 8.5". That's where the "11" and "8.5" in the code comes from. The 300 is the resolution of the printer in dots per inch (dpi). Some newer printers are now coming out with 600 or even 800 dpi. Those users may need to replace the 300 with the appropriate values for their printers.

The margins along the long dimension are 0.27" and 0.25". Their sum is:

$$0.27 + 0.25 = 0.52 \text{ inches}$$

So we need to move the x origin by:

$$11.0 - 0.52 = 10.48 \text{ inches}$$

Both margins along the short dimension are 0.25", so we move the y origin by:

$$8.5 - 0.5 = 8.0 \text{ inches}$$

If you use any other page sizes (especially if you use "Fit Page to Envelope"), you need to modify these numbers. Simply replace the "11" by the long dimension of your page and "8.5" by the short dimension of your page, expressed in inches.

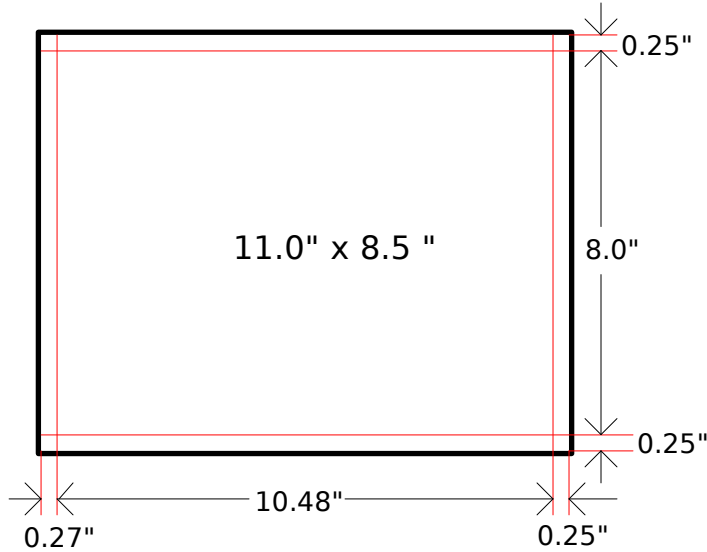

For European users, using A4 sized paper (29.7cm x 21.0 cm), the **Reverse Landscape** code is:

```
{print "29.7 2.54 div .52 sub 300 mul 21 2.54 div .5 sub
300 mul translate 180 rotate "}
```

Here we've added the conversion from centimeters to inches by dividing the page dimensions by 2.54.

If you use any other page sizes (especially if you use "Fit Page to Envelope"), you need to modify these numbers. Simply replace the "29.7" by the long dimension of your page and "21" by the short dimension of your page, expressed in centimeters.

Additionally, you may need to change "300" to match the resolution of your printer.

8.2 The best way yet to beat the smudgies

There are a couple of ways to eliminate smudging on your envelopes, each method is described in detail below.

1. If you indicated that you are using a Hewlett Packard Series III printer during installation, **Enveloper** will print your envelopes in `mode`. When an envelope travels through your printer, it develops something called "flutter", minuscule movement that causes smudging. If you use reverse landscape (thus printing the return address on the leading edge of the envelope), there is less opportunity for "flutter" to develop.
2. Flip down the exit tray, if your printer has one. The exit tray allows the paper to exit without curling back around.
3. You can buy envelopes made especially for laser printers. These envelopes are characterized by sharp, sharp folds and minimal "bulge" on the seams.

Bulges cause minute shifts in the envelope as it feeds through the printer, which in turn cause smudges.

4. One final way to defeat the "smudgies" on laser printer envelopes is to use a "**Enveloper** Cheat Sheet". This method is ideal for LaserJet series II printers. To make an "**Enveloper** Cheat Sheet", do the following:
5. Take a sheet of heavy cover stock about 30 to 40 lb. For the standard Com 10 envelopes, cut a piece of cover stock exactly four and one-sixteenth inches wide and about eight and a half inches long. A properly trimmed "**Enveloper** Cheat Sheet" should fit snugly inside your envelopes in the "short" direction, but have an inch or so of play in the "long" direction.
6. Now the next time you print envelopes, flip out the output or exit tray, if you have one. This will keep the envelope from making that last tight turn before landing in the output bin. Tuck your "**Enveloper** Cheat Sheet" under the flap of the envelope so that the Cheat Sheet is up against the return-address edge of the envelope (that is the left edge as you look at the envelope's printed side). Finally, feed the envelope through as you normally would.
7. *Notes:* The "**Enveloper** Cheat Sheet" works on laser printers that are printing in the normal landscape mode. If you have a Series III LaserJet printer, you don't need a Cheat Sheet because **Enveloper** automatically is set to print in the reverse landscape mode available on the LaserJet III Series printers. Also the Cheat Sheet doesn't improve the output when printing to a HP DeskJet printer, but it really shouldn't be needed with the DeskJet.

8.3 Accessing a Phone Book Utility

By default, the `PhoneBook...` button in **Enveloper's** dialog box hooks into the **WOPR Address Book** utility to look up an address. If you already have another Phone Book or PIM utility, you can easily customize **Enveloper** to use your utility instead! You just have to know how to coax your Phone Book utility to get the results back to you via a function call. Most of these utilities sport a Dynamic Data Exchange (DDE) or Dynamic Link Library (DLL) interface to other Windows applications. You need to consult their documentation to find out how to do it.

Once you figure that out, you just need to edit one function in **Enveloper** to complete the hook. This `GetPhoneBook$()` function is located in the `EnvHooks` macro of the `ENVR6.DOT` template in your `WINWORD\STARTUP` directory. The function has the following declaration:

```
Function GetPhoneBook$(addr$)
```

It takes a single string argument and returns another string. Typically, the input argument string is a name or partial address; you feed that string to your Phone Book utility to get the full address. Just use that full address as the return value of the function, and **Enveloper** will use it to fill in the Addressee TextBox.

To edit the macro, use the following procedure:

1. File Open the `WINWORD\STARTUP\ENVR6.DOT` document. Note that you need to adjust the path to match your setup.

2. Choose **Tools, Macro...** from the menu. Make sure the **Macros Available In:** list box reads **Envr6.dot (template)**.
3. Highlight **EnvHooks** in the **Macro Name** list, and click **Edit**.
4. Scroll down to the **GetPhoneBook\$()** function and make your changes. Use the original macro as an example.
5. When you're done, choose **File, Save All** from the menu.

Obviously, you have to be familiar with WordBasic to perform this procedure.

We'll try our best to help you make it work, but the details are very much dependent on your Phone Book utility or PIM. Try to ask their Tech Support to supply you with a WordBasic macro that does the same thing as **GetPhoneBook\$()**, then just copy it into the **EnvHooks** macro!

8.4 Accessing a Zip Code Utility

The procedure for creating a hook to your Zip Code Utility is very much the same as the procedure for creating a hook to your Phone Book Utility.

Unfortunately, we were not able to find a feasible Zip Code utility that makes this easy. The reasonably-cost ones did not provide adequate (any) Dynamic Data Exchange (DDE) or Dynamic Link Library (DLL) support, and the ones that do cost several hundred dollars....at least!

We do, however, anticipate these Zip Code utilities to get cheaper and provide better inter-application support during the life-time of **WOPR 6**, so we've provided the hook. If you already have a Zip Code utility that provides DDE or DLL support, you can easily hook it into **Enveloper!**

You just need to edit one function in **Enveloper** to complete the hook. This **FindZip\$()** function is located in the **EnvHooks** macro of the **ENVR6.DOT** template in your **WINWORD\STARTUP** directory. The function has the following declaration:

```
Function FindZip$(addr$)
```

It takes a single string argument and returns another string. Typically, the input argument string is a partial address; you feed that string to your Zip Code utility to get the full address with the Zip +4 code. Just use that full address as the return value of the function, and **Enveloper** will use it to fill in the Addressee TextBox.

To edit the macro, use the following procedure:

1. File Open the **WINWORD\STARTUP\ENVR6.DOT** document. Note that you need to adjust the path to match your setup.
2. Choose **Tools, Macro...** from the menu. Make sure the **Macros Available In:** list box reads **Envr6.dot (template)**.
3. Highlight **EnvHooks** in the **Macro Name** list, and click **Edit**.
4. Scroll down to the **FindZip\$()** function and make your changes.
5. When you're done, choose **File, Save All** from the menu.

Obviously, you have to be familiar with WordBasic to perform this procedure.

We'll try our best to help you make it work, but the details are very much dependent on your Zip Code utility. Try to ask their Tech Support to supply you with a WordBasic macro that does the same thing as `FindZip$()`, then just copy it into the `EnvHooks` macro!

9 Common Questions

This section includes some commonly asked questions and describes some work-arounds to problems. Browse through this section if you run into any problems.

9.1 Q&A Multiple Return Addresses

- Q.** I have two return addresses that I normally use. Having to switch between them is a pain, since editing envelope templates is so slow. Is there a way to switch my return addresses dynamically at ?
- A.** There is, but you have to change the way you think about envelopes. The way to get what you want is to create two envelope templates, each with its own . You can think of these as computer models of preprinted envelopes. You can customize each one to have different fonts also. At , simply choose the envelope template that corresponds to the return address you want. It's fast.

9.2 Q&A DeskJet Ejecting Page Before Printing

- Q.** Enveloper 4.0 used to work with my DeskJet, but now it's pulling the envelope all the way through and printing on the following piece of paper. What's going on?
- A.** Apparently, the WinWord 6.x and DeskJet printer driver interactions have changed. Enveloper 4.0 used printer codes to make envelopes print correctly in WinWord 2.x. That printer code is now hurting. You need to use to remove the from all your envelopes.

9.3 Q&A LaserJet 4 and Reverse Landscape...NOT

- Q.** Why is my LaserJet 4 printing barcodes upside down when I try to use Reverse Landscape?
- A.** Turns out the new LaserJet 4 printer drivers by default print graphics in HP-GL/2 mode, which ignores the Reverse Landscape Print Field. One alterna-

tive is to change your printer driver to print graphics as Raster. Not a good alternative, since that'll slow down printing.

The only real solution is to not print in Reverse Landscape. The LJ4 series seem to handle envelopes pretty well in normal landscape. To switch to Normal Landscape, you need to edit all your envelopes using . You need to remove the from all your envelopes and use the button to turn off the Reverse Landscape setting.

9.4Q&A Logo Position

Q. Enveloper seems to have its own idea of where my go. Is there any way I can change that?

A. Yes. You can reposition the logo, or any item for that matter, in the mode. Each envelope item is contained in a frame. Just move the cursor to the edge of the frame until it turns to a four-headed arrow. Then simply drag-and-drop the frame to a new location. Be forewarned, however, that you may need to reposition the logo if you change its size or replace it.

Each envelope item also belongs to a *Style*. You can move each item by choosing **Format, Style** from the menu. Choose one of the styles:

- **EnvLogo**
- **EnvNote**
- **EnvAddressee**
- **EnvRetAddr**

Then click on **Modify . . .** Click on **Format**, then select **Frame . . .** Change the position and size of the frame to your liking.

9.5Q&A Logo Overlapping Return Address

Q. My return address is overlapping the logo. How do I fix it?

A. If you set up Enveloper by telling it to use centimeters (rather than inches) to build envelopes, but WinWord is set up to use inches, then this could cause the return address to overlap the logo. You either have to use inches, or use Tools, Options, General from the menu to set WinWord to centimeters.

9.6Q&A Non-Breaking Hyphen

Q. Where did my NON-Breaking Hyphen go???

- A. Well, method apparently swallows nonbreaking hyphens (**Ctrl+Shift+Hyphen**). You need to use `.` Choose **Enveloper6 Customize** from the **Tools** menu, click on **Settings>>**, and select **SmartGrab**. Click **OK**. Run **Enveloper** again, and you should see your hyphen.

9.7Q&A Blank PostScript Envelopes

- Q. I have a PostScript printer. Envelopes look OK in Preview mode, but nothing prints. What's wrong?
- A. You probably installed `codes` rather than the **PostScript Reverse Landscape** codes. To remedy this, edit your envelope templates by choosing **Enveloper6 Customize** from the **Tools** menu. Highlight the envelope you want to fix and click **Edit...** Click **Print Field...** to see if there are any imbedded print fields. To make sure, choose **(none)**. Click the **Save as Default** button, then the **Exit&Save** button.

Now you need to make a change to your WIN.INI. See the answer to the following question on how to make the change.

9.8Q&A Upside-Down Envelope

- Q. I have a PostScript printer and just upgraded to Windows 3.1. Now all my envelopes are printing upside down. What happened?
- A. Microsoft changed the PostScript printer driver to print "Normal Landscape" in Windows 3.1. The easiest way to fix it is to add a line in your WIN.INI file.

Open your WIN.INI file with an ASCII text editor (make a backup first!). Look for the section starting with `[Devicename,Port]`, where *Devicename* matches your printer and *Port* is your printer port. Add the line, **LandScapeOrient=270**. For example:

```
[HP LaserJet III PostScript,LPT1]
LandScapeOrient=270
```

9.9Q&A Envelope Feeder

- Q. I have an envelope feeder for my laser printer, but the printer driver keeps complaining that it can only print envelopes and refuses to print.?
- A. Most printer drivers are very picky when you use the envelope feeder. It won't allow you to send a letter-size page to the printer....even though the

envelope image is placed correctly. To remedy this, you need the setting in *Enveloper*.

To make the change, choose **Enveloper6 Customize** from the **Tools** menu. Select your envelope and click **Edit...** Click on **Printer & Zip Settings...**, then choose the **Fit Page to Envelope** check box in the **Feed Method** section. Click on **<<Back**, then **TestPrint** to try it out. Click on **Exit&Save** to save all changes.

9.10Q&A Margin Errors

- Q.** I keep getting **Margins are set outside printable area** errors, but the envelope prints fine. How can I get rid of these messages?
- A.** You need to adjust the standard margins that *Enveloper* uses for its envelopes. Choose **Enveloper6 Customize** from the **Tools** menu. Select your envelope and click **Edit...** Click on **Printer & Zip Settings...**, and make changes to the margins. To find the proper minimum margins for your printer, you can use the **WOPRMinMargins** utility macro. Follow the directions in the Section to see how to do this.

9.11Q&A Cut-Off Bar Codes

- Q.** I'm using an envelope printing format that aligns the envelope at the bottom edge of the page. The problem is that the bar codes are getting cut off. I tried moving it, but it always ends up in the same place. How can I change this?
- A.** To protect against accidental moves, *Enveloper* resets the bar code position whenever you exit mode. This is because the bar code has to be in a fairly precise location, unlike the other items on the envelope. To really move the bar codes, you need to edit your envelope template with **Enveloper6 Customize** from the **Tools** menu. Choose **Printer & Zip Settings...** and change the barcode location. You may want to just use the **Above Addressee** setting to avoid the problem altogether. See the Section for more detailed explanation and for the bar code requirements.

9.12Q&A Wrong Addressee Position

- Q.** When I print an envelope, the addressee prints near the top, where the return address should be. What went wrong?

- A.** You probably tried to manually delete the return address when in the `mode`. This is not allowed, since it could screw up the bookmarks that **Enveloper** depends on for proper operation. If you don't need a return address, use the `(blank)` return address when you edit the envelope template.

There is no fix for this problem, you need to create your envelope again.

9.13Q&A Upside-Down Logo

- Q.** How come my `is` printing upside-down, and completely off the envelope? When I feed a letter-sized paper through instead of the envelope, the logo is at the bottom edge of the piece of paper.

- A.** You must be using `printing` to print the return address first. And you must be using a Print Field to turn on the **Reverse Landscape** mode. The problem is that the Logo is printing before the Print Field, so that the printer doesn't know the you want to print **Reverse Landscape** until after the Logo has printed already.

To fix this, go into `mode` and drag the Logo down a little and to the right a little. Hopefully, this will be enough to make the Print Field print first. Click the Printer Tool in the floating **Enveloper Manual Edit** toolbar to test it.